

HP ProLiant DL785 G5

Internal Options:

Optional P5--P8 CPUs

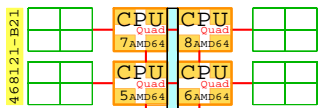

4x Opteron 8354, 2200MHz
Cache 2MB/core,
No memory

- 408851-B21 2GB
- 408853-B21 4GB
- 408854-B21 8GB
- 437572-B21 G5 2nd power
- 431933-B21 36GB 15k SAS
- 431935-B21 72GB 15k SAS
- 431958-B21 146GB 10k SAS
- 367047-B21 NC320T 1000T PCI-E Gigabit
- 414126-B21 NC510F One Port PCI-E 10-Gigabit
- A8003A FibChan PCI-E HBA 2ch 4Gb FC2242SR
- 405132-B21 SA P400/256 PCI-E

Example Configuration

AMD64 Opteron 8356

2300MHz 4P-Quad AH260A

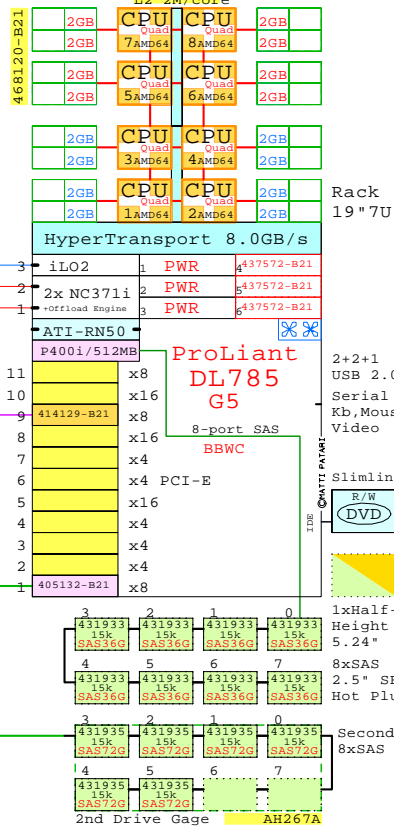

Rack 19" 7U

ProLiant DL785 G5

Parts list for the 8P Quad-Core Opteron 8356 system above

Part Number	Qty	Description
1 AH260A	1	DL785 G5 4P QC AMD8356 4x2MB 16GB 2.3GHz
1.1 405132-B21	1	HP Smart Array P400/256 PCI-E HBA
1.2 414129-B21	1	HP NC510C PCI-E 10-Gigabit Server Adapte
1.3 431933-B21	8	HP 36GB SAS 15000r hot-plug disk 2.5"
1.4 437572-B21	3	DL580 G5 second power supply WW
1.5 468120-B21	1	5-8P CPU AMD64 QC 8356 2.30GHz DL785 G5
1.5.1 408851-B21	8	2GB PC2-5300 DDR2 kit 2x1GB DL385G2
1.6 AH267A	1	2nd Drive Gage 8xSFF SAS DL785 G5
1.6.1 431935-B21	6	HP 72GB SAS 15000r hot-plug disk 2.5"

Link to this document:

<http://goldeneggs.spyderbyte.com/geggs/GEODL785G5x.pdf>

For more detailed configuring, please consult the latest HP QuickSpecs or VisioCafe.com
All trademarks in this document are those of their owners.

Optional P5--P8 CPUs

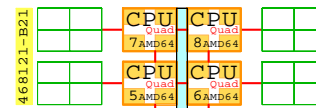

468121-B21
4x Opteron 8354,
Cache 2MB/core,
No memory

- iLO2 RJ-45 10/100
- 2x RJ-45 10/100/1000
- ATI ES1000 32MB
- 8-port SAS Raid, 256
- 5x PCI-E x4 Full-size
- 3x PCI-E x8 Full-size
- 3x PCI-E x16 Full-size

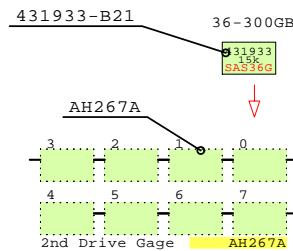

2200MHz 8xQuad-Core

AMD64 Opteron 8354

2200MHz 4P-Quad AH261A

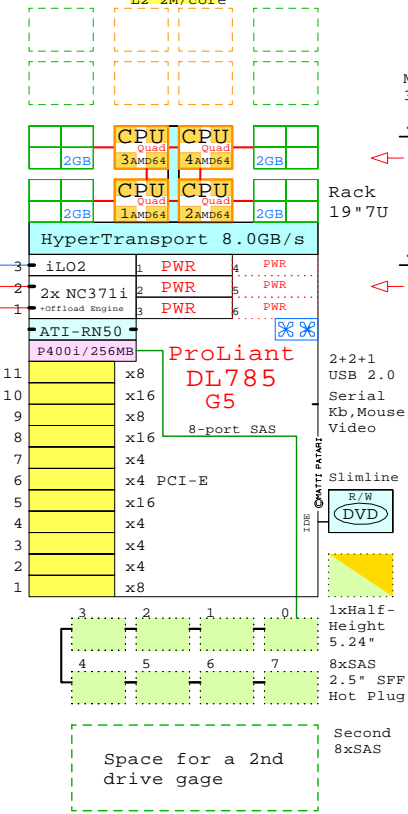

Rack 19" 7U

ProLiant DL785 G5

More DL785 G5 systems are serviced on page 2

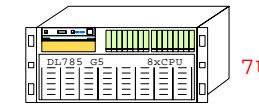

DL785 G5
AMD64

MS Windows Server 2003 - 2008
LINUX: Red Hat, SuSE
VMware Virtualization Software

<http://www.LinuxHPC.org>
<http://www.WinHPC.org>

Golden Eggs home:
<http://goldeneggs.spyderbyte.com/>

© 2008 Matti Patari, All rights reserved.

GOLDEN EGGS Visuals™ Helsinki	14-May-2008	GEODL785G5a
		Matti.Patari@Kolumbus.Fi

HP ProLiant DL785 G5 8354 2200MHz
GOLDEN EGGS Visuals, Helsinki

Matti.Patari@Kolumbus.Fi

Golden Eggs home:

<http://goldeneggs.spyderbyte.com/>

Optional P5--P8 CPUs

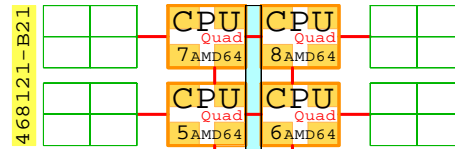

468121-B21

4x Opteron 8354,
Cache 2MB/core,
No memory

-iLO2 RJ-45 10/100

-2x RJ-45 10/100/1000

-ATI ES1000 32MB

-8-port SAS Raid,256

-5x PCI-E x4 Full-size

-3x PCI-E x8 Full-size

-3x PCI-E x16 Full-size

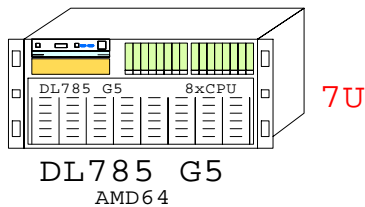

Gigabit E
Gigabit E
iLO2 Remote Manager

2200MHz 8xQuad-Core

AMD64 Opteron 8354

2200MHz 4P-Quad AH261A

L2-2M/core

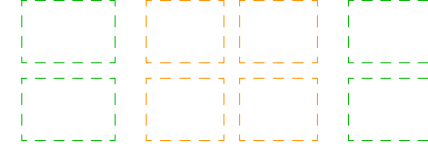

Memory Max:
32x8GB=256GB

408851-B21

2GB

Rack
19"7U

DIMM pair
2x 1GB

437572-B21

437572-B21

Optional
Power supply

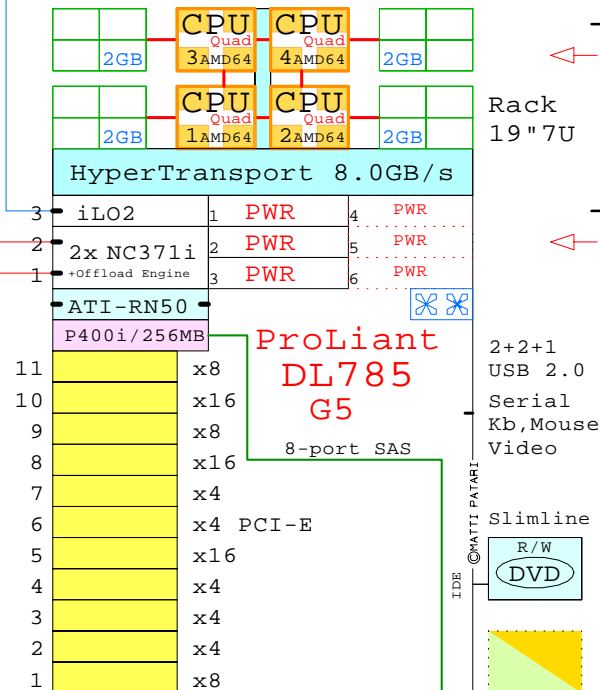

ProLiant
DL785
G5

- 11 x8
- 10 x16
- 9 x8
- 8 x16
- 7 x4
- 6 x4 PCI-E
- 5 x16
- 4 x4
- 3 x4
- 2 x4
- 1 x8

2+2+1
USB 2.0
Serial
Kb,Mouse
Video

Slimline
R/W
DVD

1xHalf-
Height
5.24"
8xSAS
2.5" SFF
Hot Plug

Second
8xSAS

431933-B21

36-300GB

31933
15k
SAS36G

AH267A

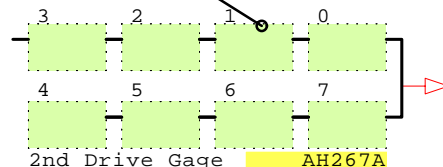

2nd Drive Gage AH267A

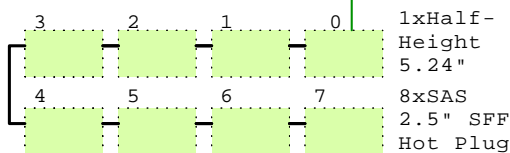

Space for a 2nd
drive gage

Link to this document:

<http://goldeneggs.spyderbyte.com/geggs/GEODL785G5x.pdf>

HP ProLiant DL785 G5 Example Configuration

AMD64 Opteron 8356

2300MHz 4P-Quad AH260A

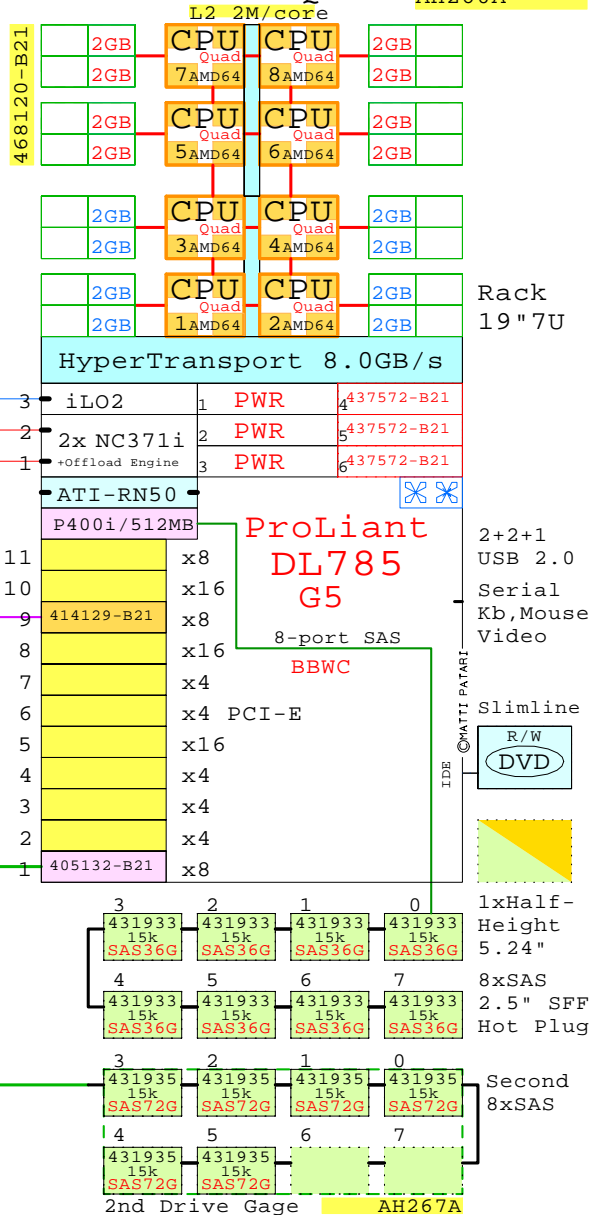

Parts list for the 8P Quad-Core Opteron 8356 system above

	Part Number	Qty	Description
	AH260A	1	DL785 G5 4P QC AMD8356 4x2MB 16GB 2.3GHz
1.1	405132-B21	1	HP Smart Array P400/256 PCI-E HBA
1.2	414129-B21	1	HP NC510C PCI-E 10-Gigabit Server Adapte
1.3	431933-B21	8	HP 36GB SAS 15000r hot-plug disk 2.5"
1.4	437572-B21	3	DL580 G5 second power supply WW
1.5	468120-B21	1	5-8P CPU AMD64 QC 8356 2.30GHz DL785 G5
1.5.1	408851-B21	8	2GB PC2-5300 DDR2 kit 2x1GB DL385G2
1.6	AH267A	1	2nd Drive Gage 8xSFF SAS DL785 G5
1.6.1	431935-B21	6	HP 72GB SAS 15000r hot-plug disk 2.5"

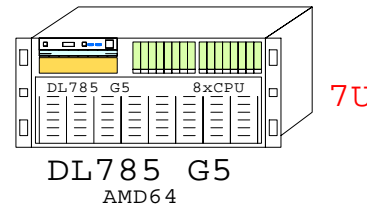

Matti.Patari@Kolumbus.Fi

Golden Eggs home:
<http://goldeneggs.spyderbyte.com/>

Link to this document:
<http://goldeneggs.spyderbyte.com/geggs/GEODL785G5x.pdf>